

MEDIUM INTENSITY



MEDIUM INTENSITY OBSTRUCTION LIGHT



According to ICAO - Annex 14 Medium Intensity Obstruction Lights - Type A, B or C - have to be used where the obstacle is particularly large and the height of the surrounding soil is more than 45m.

Medium Intensity Obstacle Lights Type A and C have to be used alone, whereas Medium Intensity Obstacle Lights, Type B, should be used either alone or in combination with Low Intensity Obstacle Lights, Type B.

The Medium Intensity Obstruction Lights Type A is white flashing.

The Medium Intensity Obstruction Lights Type B is red flashing.

The Medium Intensity Obstruction Lights Type C is red steady burning.



LUXSOLAR beacons are composed of a plurality of separated lenses not belonging to the central body of the beacon. This allows the lenses to be coupled by distinct clamping elements.

MEDIUM INTENSITY

MIOL-B / MIOL-C

Patented chimney effect for optimum cooling of the beacon

Borosilicate glass cover protection

Stabilised light output: 2.000cd

Standard circuits or TWIN*

Patented optical lens fastened with metal clamps

Anti-condensation Gore-Tex valve

Anodised aluminium body

Infrared version*

Based on LED technology
Red flashing light (MIOL-B)
Red steady burning light (MIOL-C)

Spirit level

Power connector
PLUG&PLAY: IP68/69k

Air-cooling system for +65% heat dissipation

IP66

* as option

International patents: granted and pending

Medium Intensity Obstruction Light is according to ICAO (Medium Intensity – Type B or C), FAA (Type L-864) and ENAC certified.

This beacon is equipped with a patented air-cooling system, based on the “Venturi Effect”, increasing the heat dissipation due to wind.

Thanks to a **lifetime >10 years** and a **low power consumption**, this beacon is the ideal solution for an **efficient, lightweight** and **compact** obstruction signalling. The circular shape of the device allows reducing the wind load factor [Wind resistance tested at 240km/h (150mph)], and guarantees an omnidirectional light propagation.

MIOL-B emits a **red flashing light**, while **MIOL-C** emits **red steady burning light**.

CERTIFICATIONS



COMPLIANCE



FEATURES

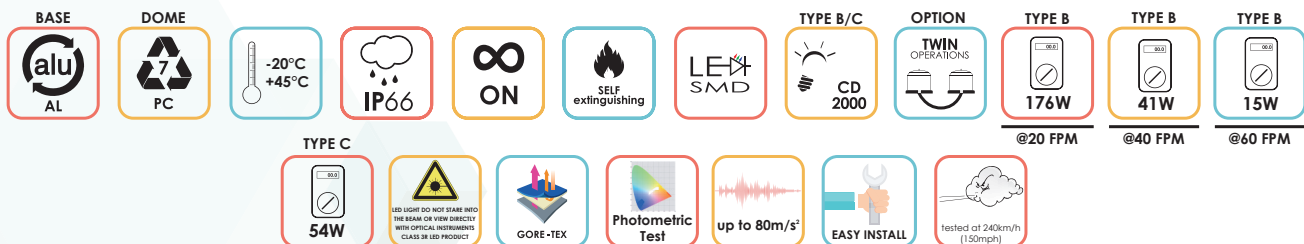

APPLICATIONS



MEDIUM INTENSITY

MIOL-B and MIOL-C TECHNICAL SPECIFICATIONS

OPTICAL FEATURES

- Based on LED technology
- RED light 2.000cd
- Cd emission @ -0,5° and +4°
- Horizontal beam radiation: 360°
- Vertical beam spread: 4°
- PMMA lens (PMMA)
- Light output alignment device

GENERAL OPTIONS

- Beacon support bracket
- Flow deflector
- Horizontal beam radiation: 180°
- Power supply AC or DC
- GPS (Global Position System) Sync
- Infrared version

TWIN VERSION OPTIONS

- Twin version: two galvanically separated circuits in the same fixture
- Fault alarm
- Automatic changeover from normal to backup light
- Infrared version

MECHANICAL FEATURES

- Borosilicate glass cover protection
- RAL 7035 painted aluminium body lamp
- Silicon gasket
- Bottom wind collector for central heat-sink cooling
- Degree of protection: IP66
- Anti-condensation Gore-Tex valve
- Wind resistance tested at 240km/h (150mph)
- Vibration resistance up to: 80m/s² (10° Mercalli Intensity Scale / 7° Richter Magnitude Scale)
- Operating temperature: -20°C to +45°C
- Storage temperature: -20°C to +45°C
- Lamp unit weight: 6kg

ORDER CODE

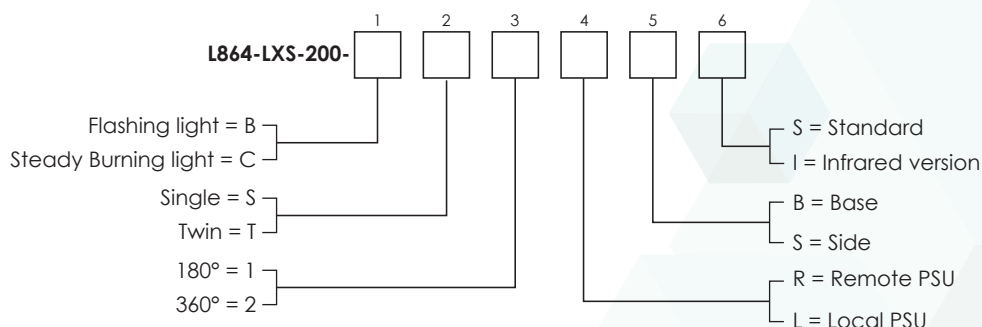

INFRARED VERSION OPTIONS

- IR Wavelength - 850nm

ELECTRICAL FEATURES

- Alarm/remote status control
- Electronic control parts installed outside the beacon (see pag. 30)
- Average power consumption for MIOL-B:
 - @20fpm: 9W
 - @40fpm: 12W
 - @60fpm: 15W
- Average power consumption for MIOL-C (Steady Burning): 54W
- LED feeded at constant current
- Lightning protection
- No RF-radiations
- Range section of connectable conductors: 0,5mm² to 2,5mm²
- Cable outer diameter range: 7mm to 14mm

APPLY TO

- Airport - Stack - High building - Chimney - Tower crane
- Pipe line - Bridge - Radio and television tower
- Transmission line - Wind turbine - Wind mast measurement
- Radar - Antenna

CERTIFICATIONS

- DGAC/STAC approval nr. 2013A037
- ENAC approval nr. 0135182/ENAC/CIA
- CE marking

COMPLIANCE

- ICAO Aerodromes -Annex 14 Vol. 1, Chap. 6: Medium intensity, Type B flashing obstacle light MIOL-B type or Type C steady burning obstacle light MIOL-C type
- FAA AC150/5345-43F E.B. #67 type L-864 o Twin L-864
- Licensing of aerodromes - CAP168 - Chapter 4

MEDIUM INTENSITY

MIOL-B and MIOL-C TECHNICAL SPECIFICATIONS

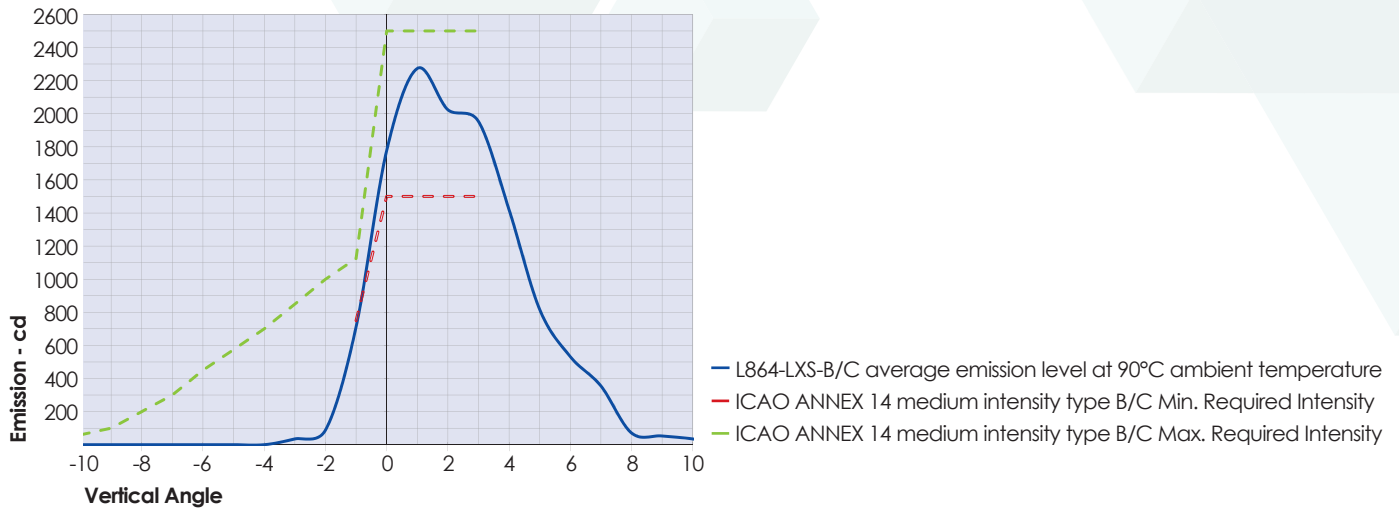

SINGLE VERSION
SIDE VIEW

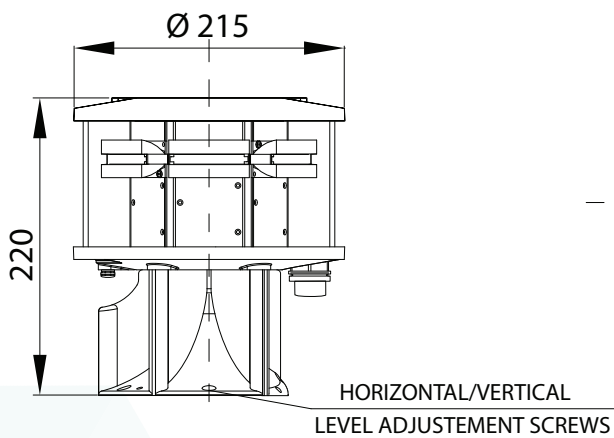

TOP VIEW

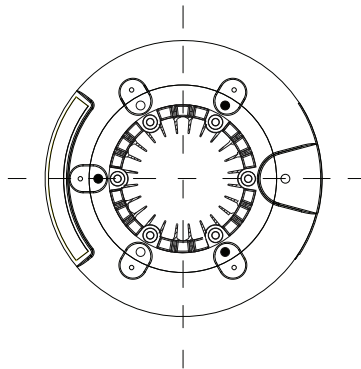

TWIN VERSION
SIDE VIEW

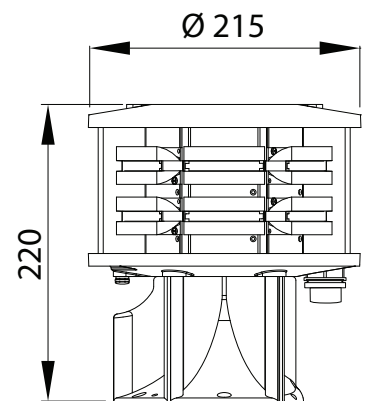

BOTTOM VIEW

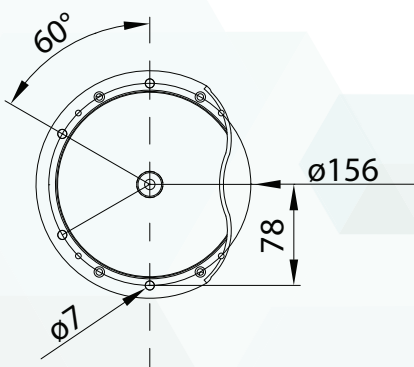

BOTTOM VIEW
WITHOUT WIND
COLLECTOR

